

OAenterprise®, developed by ObjectAutomation®, is a software system conceived and designed as an open, industrial automation (IA) software tool set that fosters rapid IA application development for any automation process. From motion control, discrete control, batch, process control to execution systems, OAenterprise offers universal control for IA, with complete connectivity to the various ERP layer programs.

OAenterprise, designed as an Object-Based™ environment, is based upon Microsoft technologies, to achieve the complete utilization of the PC, the Internet and their derivatives. OAenterprise was conceptualized two years prior to Microsoft's unveiling of DNA for Manufacturing (DNAM); interestingly enough, the implementation of OAenterprise is an extraordinary realization of the DNA-M tenets currently seen.

When ObjectAutomation was founded to build its software upon the Microsoft platform of technologies, there were a number of speculative decisions made in regard to the developmental path of OAenterprise.

These decisions are as follows:

- DCOM was chosen as the basis for object interoperability, even though DCOM was still in a pre-release form.
- OA had considered a number of CORBA-based object management tools, but opted for the more flexible DCOM, in confident anticipation of Microsoft's architecture to be revealed.
- Windows 2003 Server, XP Pro and Win32 with its rich "plumbing and wiring" was selected as the basis for the object framework built on DCOM.
- ODBC for SQL server was chosen in anticipation of OLE-DB capability, now defined for DNAM.
- MSC++, MJ++, Internet Explorer, Visual Studio, Microsoft's Java Virtual Machine, SQL and Jet engines, Jscript and VBscript and MFC were all chosen as the fundamental building blocks for the OAenterprise.
- OA2mfxg, targeting the MES/Batch area, and OAenterprise's ERP connectivity, was built using Microsoft's Message Queue (MSMQ) and Transaction Server (MTS) as well as leveraging Extended Markup Language (XML).

Implementing solutions according to Microsoft's DNA for Manufacturing strategy provides a solution set giving applications developers freedom... the freedom to solve problems without having to worry about the low-level, underlying technologies for inter-process communications, object lifecycle, network protocol, storage access and retrieval or user interface.

Using DNA-M is not about how many of Microsoft's 'cool technologies' one is able to harness into a single software package, but rather, is an opportunity to leverage Microsoft's hard work and vision, by producing an object-based solution set that achieves the ultimate objective: to reduce the end-user's Total Cost of Ownership (TCO) for industrial solutions.

Lower TCO is achieved when the manufacturer is able to produce higher quality products at a faster rate and at a lower cost than previously executed.

How is this accomplished? There are several factors that OAenterprise, as a DNA-M solution set provides, to achieve lower TCO.

The most important of these factors include:

1. OAenterprise makes the end-user's job far easier by reducing the amount of work required to create industrial automation applications. The end-user is able to focus on the IA solution, rather than the lower level "plumbing and wiring" protocols and database structures. This is accomplished through the common object model (COM) and the open tool set of OAenterprise that leverages not only the Microsoft technologies, but also the clever implementations of third party developers, providing "best-of-breed" solutions that naturally integrate with their DNA-M brethren.
2. OAenterprise leverages the PC and the Internet to their utmost technological capabilities. All applications built around DNA-M, including OAenterprise, provide a common user interface, common administration and security models and familiar software tools. User training and long-term application maintenance are reduced to a fraction of that derived from the wide disparity of closed, proprietary systems of the past.
3. OAenterprise leverages commodity, open hardware and discourages closed-ended, proprietary, hardware implementations. This dramatically decreases the cost of industrial automation due to the

- lower cost of commodity hardware, in combination with the opportunity of hardware unit replacement, from a variety of vendors.
4. OAenterprise encourages third party software suppliers to extend its solution set through an open set of interfaces, based on the DNA-M model. This will provide end-users with a choice of "best-of-breed" suppliers at the functional level. The end-user will no longer be imprisoned by the historical "all or nothing" approach of IA suppliers.
 5. OAenterprise fulfils the long-standing promise of object-oriented technologies (OOT), by providing reusable software components within its set of tools. Based on COM, these reusable software components are the common object model that is the basis of DNA for Manufacturing. Now users can develop objects using ObjectAutomation's rich, IA-specific development tools, those from third parties or the more general tools directly from Microsoft, then reuse those objects throughout the IA application. The end-user will never again have to endure the insanity of performing the same development work time and time again.
 6. OAenterprise encourages users to "encapsulate" their legacy solutions and evolve away from them, rather than insist that users instantly cast their legacy solutions aside to accommodate new technology. Thus, a legacy IA application that is working, but difficult to extend through traditional means, can be encapsulated with OAenterprise, through OPC, VBA or OAClassServer™ tools, providing higher levels of control, functional enhancement, access to execution class tools and links to standard databases and ERP.

DNA for Manufacturing Model

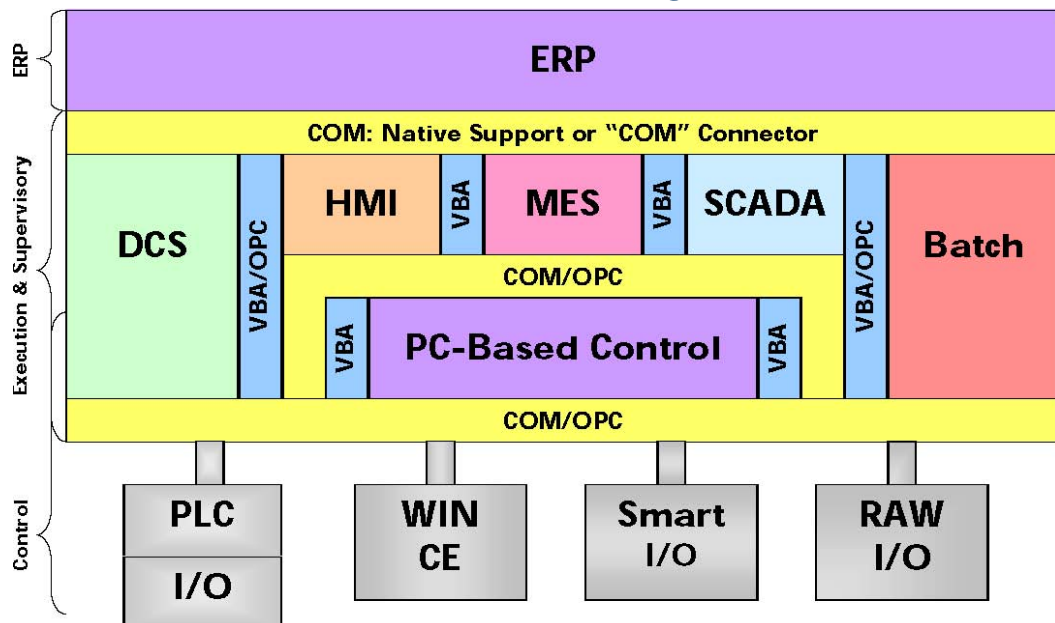

Figure 1

This diagram depicts the three levels of classic Computer Integrated Manufacturing (CIM) architectures: Control, Execution Systems and Supervisory Control and Enterprise Resource Planning (ERP).

Note the overlap between the Control and Supervisory Control layers to demonstrate how some of the DCS, Batch and certainly PC-based control solutions span both of these layers.

As shown in Figure 1, Microsoft's DNA-M model displays ERP as a continuum, as the respective vendors represented by that space continue to offer only an "all or nothing" solution, rather than an open set of interchangeable tools.

The DNAM architecture does, on the other hand, provide for such interoperability among the various IA suppliers in the Execution Systems and Supervisory Control layers through COM, VBA, OLEDB and OPC technologies.

Furthermore, interface to the Control layer is shown as accomplished with OPC and COM interfaces.

OAENTERPRISE Model

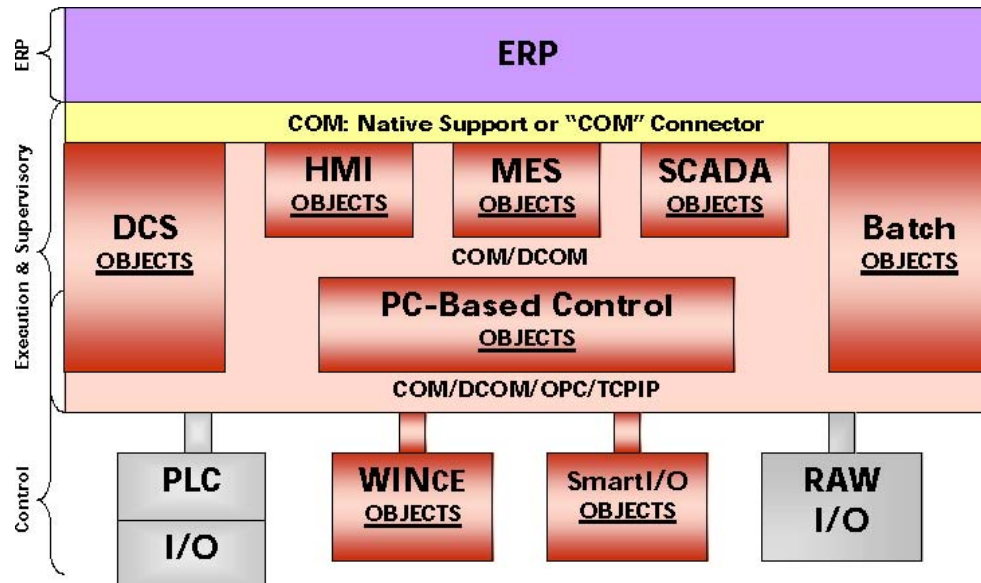

Figure 2

In Figure 2, the functional elements are entirely comprised of distributed objects that interoperate through the DNAM/COM model. The objects may be developed through a wide variety of tools available from ObjectAutomation, Microsoft and third party suppliers.

The OAenterprise provides a distributed object lifecycle management tool called the OAframework that extends Windows/NT and COM+ models for industrial automation applications. OAenterprise also provides a development workbench, the OAworkbench, based on the Internet Explorer where objects are depicted, arranged and interconnected graphically.

HTML pages are provided via URL, locally or via the Internet, for system-wide and object-specific documentation. The graphical depiction of objects is accomplished through a "view" window that supports animated graphics, including ActiveX. Using OAenterprise, all object attributes can be logged into multiple, redundant history vaults and/or via OLEDB, to standard databases like SQL server. All object attributes can be enabled to log "out-of-bounds" conditions, such as industrial alarms, through redundant alarm management objects, provided within the OAenterprise.

Conclusion

No single supplier is able to provide all solutions for the industrial enterprise.

The industry needs a comprehensive set of cohesive solutions that maximize the software resources of multiple industrial automation vendors to meet the demands of greater throughput and higher quality at a lower cost.

This requires an architecture like Microsoft's DNA for Manufacturing that encourages IA vendors to open up their solutions and extend their models through third party resources to meet the demands of the industry.

ObjectAutomation provides a comprehensive set of extensibility toolkits that enable third party developers and systems integrators to rapidly extend the object model and thus create unprecedented customization in solutions for their customers.

This open and extensible nature of OAenterprise encourages these users to pick and choose from a virtual buffet of plug-in tools, such as SPC/SQC, electronic document management, maintenance management, extended vertical market MES and Batch functionality, unique high-level control algorithms ... the wellspring of solutions available using OAenterprise is limited only by the individual's imagination.